

Driven by
engineering excellence.



WB 1011851 / 07.2008 - We reserve the right to make technical changes.

Toyota

Sortimo®

with Sortimo's unique racking solution



A place for everything ...

► www.sortimo.co.uk

Sortimo®

Sortimo International Limited
Old Sarum Park · Salisbury · Wiltshire SP4 6EB
Freephone 08000 27 5644
Phone +44 (0) 1722411585
Fax +44 (0) 1722320831
vanrack1@sortimo.co.uk

Sortimo®
inside



Form, Function, Flexibility.



Superior storage.

Your Toyota commercial vehicle and Sortimo Globelyst.

You have chosen a Toyota because it suits your space requirements, and has the quality you need for your trade and service. Globelyst the innovative in-vehicle equipment from Sortimo has less weight due to an Alu-Space-Frame structure. This gives your Toyota better space and weight utilization. With our starter kit you can organize your vehicle for more efficient use.

You can personalize your Sortimo system exactly to your own requirements at any stage by choosing from the range of Sortimo accessories.



Alu-Space-Frame Architecture

Weight reduction has always occupied Sortimo. Especially when stability and strength are required, Sortimo sets new standards.

Floor and wall protection

Soboflex Safety Flooring, Sowaflex Wall & Door kits protect your investment and your vehicle against internal damage. Sortimo racking is secured into the Safety Flooring & not the vehicle's floor pan, making re-installation easier, providing a proven Crash Tested Foundation which avoids the need to drill through the vehicle.

Variations on a theme – as an individual

There is no need to compromise. Even your most exclusive needs can be met with our Sortimo Globelyst system. Irrespective of the combinations chosen, Globelyst offers the perfect vehicle racking solution at a competitive price, coupled together with the highest safety standards.



S-Boxes

M-Boxes

Drawers

Component & tool service cases

Sobogrip/Soboflex Safety floor

Sowaflex wall protection and front cover

Toyota Hi-Ace SWB



Passenger side.

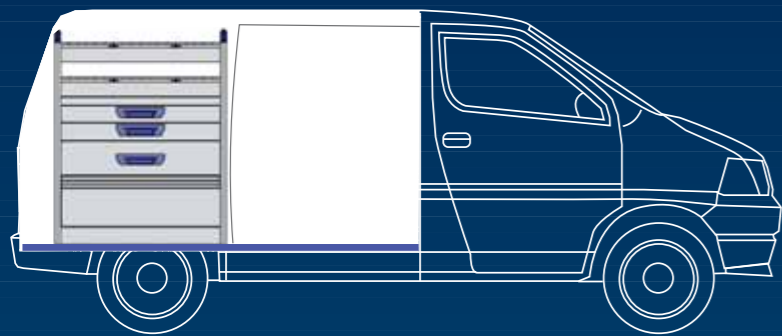

flooring

By securing the racking into Sortimo's CNC milled Sobo-safety flooring (not the van's floor pan) installation is quicker, easier & best insures your safety in the event of an accident.



HES M1

Description: Alternative to wood

- ▶ aluminium uprights
- ▶ 3 aluminium open trough shelves
- ▶ kick plate & polyprop ends

Dim: (H x W x D) 1260 x 1004 x 385 mm
Weight: 17 kg



HES M2

Description: Shelves + Boxes

- ▶ aluminium uprights
- ▶ 6 slide-out 'S'boxes
- ▶ 2 alu open shelves with mats & dividers
- ▶ lift-up wheel arch cover & polyprop ends

Dim: (H x W x D) 1260 x 1004 x 385 mm
Weight: 25 kg



HES M3

Description: Boxes

- ▶ aluminium uprights
- ▶ 6 slide-out 'M'toolboxes
- ▶ 2 slide-out 'M'toolboxes
- ▶ 2 large Euro boxes
- ▶ lift-up wheel arch cover & polyprop ends

Dim: (H x W x D) 1260 x 1004 x 385 mm
Weight: 30 kg



HES M4

Description: Shelves + Drawers

- ▶ aluminium uprights
- ▶ 2 alu open shelves with mats & dividers
- ▶ 3 drawers with mats & dividers
- ▶ lift-up wheel arch cover & polyprop ends

Dim: (H x W x D) 1260 x 1004 x 385 mm
Weight: 46 kg

Driver side.



wall & upper door

Sowaflex wall & door upper protection kits are CNC milled with fittings & locations. Using a honeycomb polyprop construction weight is kept to a minimum, providing an oil & chemical resistant, durable wipe clean finish.



HES M5

Description: Alternative to wood

- ▶ aluminium uprights
- ▶ 6 aluminium open trough shelves
- ▶ kick plate & polyprop end panels

Dim: (H x W x D) 1260 x 2000 x 385 mm
Weight: 27 kg



HES M6

Description: Shelves + Boxes

- ▶ aluminium uprights
- ▶ 12 slide-out 'S'boxes
- ▶ 4 aluminium open trough shelves with mats & dividers
- ▶ 2 lift-up wheel arch covers & polyprop ends

Dim: (H x W x D) 1260 x 2000 x 385 mm
Weight: 44 kg



HES M7

Description: Boxes

- ▶ aluminium uprights
- ▶ 12 slide-out 'S'boxes
- ▶ 4 slide-out 'M'toolboxes
- ▶ 4 large Euro boxes
- ▶ 2 lift-up wheel arch cover & polyprop ends

Dim: (H x W x D) 1260 x 2000 x 385 mm
Weight: 53 kg



HES M8

Description: Drawers + Cases

- ▶ aluminium uprights
- ▶ 5 alu open shelves with mats & dividers
- ▶ 3 drawers with mats & dividers
- ▶ 1 component case, 1 tool case on runners
- ▶ lift-up wheel arch cover & polyprop ends

Dim: (H x W x D) 1260 x 2000 x 385 mm
Weight: 79 kg

All of the above systems use the same Aluminium space-frame, so can be upgraded as your requirements change. Shelf positions can be changed easily a 17mm increments up or down the space point of installation.

Buy any combination of Driver side, Passenger side & Floor, and Save 10%

Toyota Hi-Ace LWB



Passenger side.

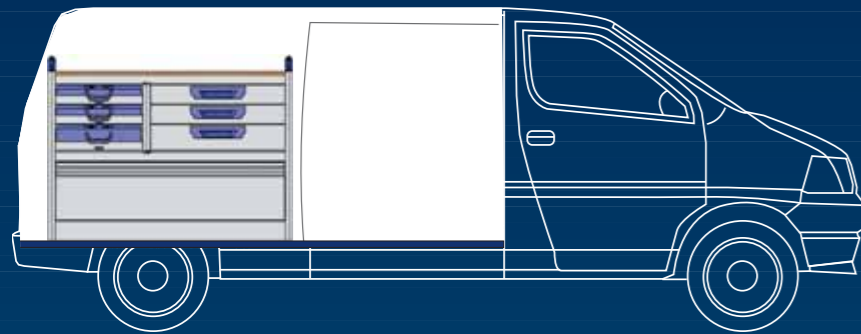

flooring

By securing the racking into Sortimo's CNC milled Sobo-safety flooring (not the van's floor pan) installation is quicker, easier & best insures your safety in the event of an accident.



HEL L1-1

Description: Alternative to wood

- ▶ aluminium uprights
- ▶ 3 aluminium open trough shelves
- ▶ kick plate & polyprop ends

Dim: (H x W x D) 1260 x 1250 x 385 mm
Weight: 19 kg



HEL L1-2

Description: Shelves + Boxes

- ▶ aluminium uprights
- ▶ 7 slide-out 'S'boxes
- ▶ 2 alu open shelves with mats & dividers
- ▶ lift-up wheel arch cover & polyprop ends

Dim: (H x W x D) 1260 x 1250 x 385 mm
Weight: 30 kg



HEL L1-3

Description: Boxes

- ▶ aluminium uprights
- ▶ 9 slide-out 'M'toolboxes
- ▶ 2 slide-out 'M'toolboxes
- ▶ 2 large & 2 small Euro boxes
- ▶ lift-up wheel arch cover & polyprop ends

Dim: (H x W x D) 1260 x 1250 x 385 mm
Weight: 35 kg



HEL L1-4

Description: Workbench

- ▶ aluminium uprights
- ▶ HD wooden work surface
- ▶ 1 component & 2 tool service cases mounted on runners
- ▶ 3 drawers with mats & dividers
- ▶ lift-up wheel arch cover & polyprop ends

Dim: (H x W x D) 940 x 1250 x 385 mm
Weight: 65 kg

Driver side.

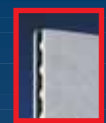
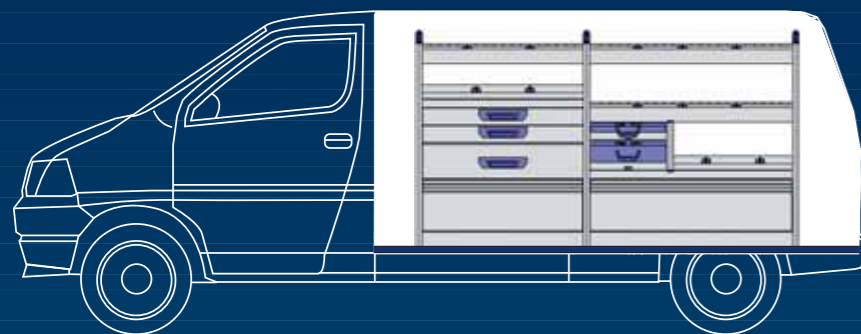

wall & upper door

Sowaflex wall & door upper protection kits are CNC milled with fittings & locations. Using a honeycomb polyprop construction weight is kept to a minimum, providing an oil & chemical resistant, durable wipe clean finish.



HEL L1-5

Description: Alternative to wood

- ▶ aluminium uprights
- ▶ 6 aluminium open trough shelves
- ▶ kick plate & polyprop end panels

Dim: (H x W x D) 1260 x 2250 x 385 mm
Weight: 29 kg



HEL L1-6

Description: Shelves + Boxes

- ▶ aluminium uprights
- ▶ 13 slide-out 'S'boxes
- ▶ 4 aluminium open trough shelves with mats & dividers
- ▶ 2 lift-up wheel arch covers & polyprop ends

Dim: (H x W x D) 1260 x 2250 x 385 mm
Weight: 48 kg



HEL L1-7

Description: Boxes

- ▶ aluminium uprights
- ▶ 14 slide-out 'S'boxes
- ▶ 4 slide-out 'M'toolboxes
- ▶ 4 large & 2 small Euro boxes
- ▶ 2 lift-up wheel arch cover & polyprop ends

Dim: (H x W x D) 1260 x 2250 x 385 mm
Weight: 59 kg



HEL L1-8

Description: Drawers + Cases

- ▶ aluminium uprights
- ▶ 5 alu open shelves with mats & dividers
- ▶ 3 drawers with mats & dividers
- ▶ 1 compartment case, 1 tool-case on runners,
- ▶ 2 lift-up wheel arch cover & polyprop ends

Dim: (H x W x D) 1260 x 2250 x 385 mm
Weight: 84 kg

All of the above systems use the same Aluminium space-frame, so can be upgraded as your requirements change. Shelf positions can be changed easily a 17mm increments up or down the space point of installation.

Buy any combination of Driver side, Passenger side & Floor, and Save 10%

Sortimo original accessories

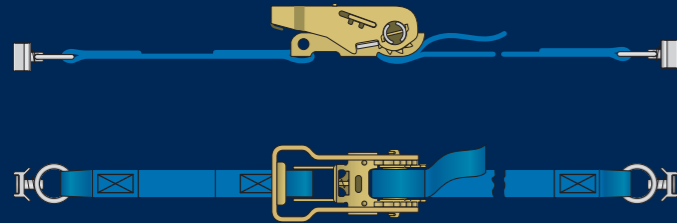

01 ratchet strap to suit tracking

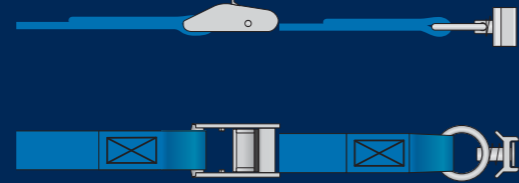

02 pinch strap to suit tracking



19 16 watt 12 v strip light



20 360° swivel for vice



21 vice 120 mm jaws (forged steel)



03 lashing track Q/R eye



04 floor eyelet



05a end panel lashing track
05b bulkhead lashing track 1m



06 floor lashing track 1.5m



07 front racket pocket



08 document pocket



09 cable holder



10 perfo hooks - 18 piece set



22 perfo end panel upgrade (without hooks and tools)



23 T-BOXX



11 hook



12 ladder hook



13 coat hook



14 cam clamp



15 cone / holder set



16 paper towel holder



17 waste basket



18a fire extinguisher 2 kg
18b fire extinguisher 6 kg



24 12 V hot & cold handwash

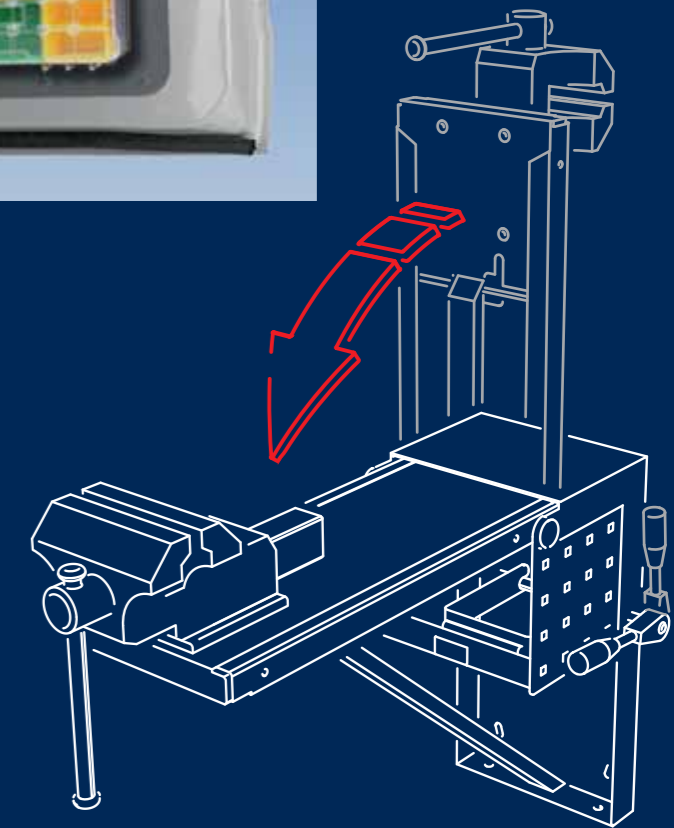

25 drop-down platform without vice, (check suitability)

